



Billet LS Alternator Bracket

High Mount Passenger Side Kit

i n s t a l l a t i o n i n s t r u c t i o n s



#CBM-10747-2-KIT

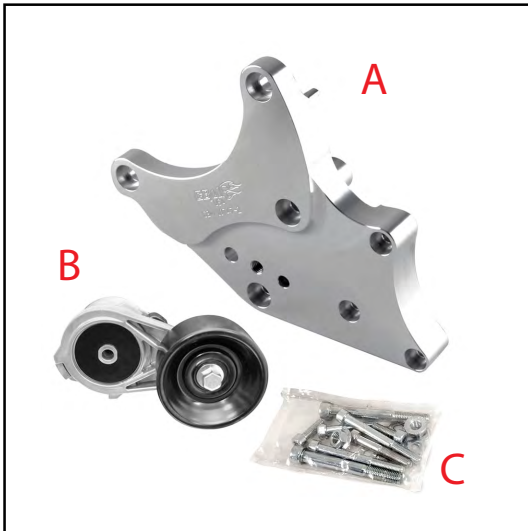

What is in the box?

- A) 1 Billet LS alternator bracket.
- B) 1 Belt tensioner with pulley.
- C) 1 Bolt kit.
*x1 10mm x 65mm, x1 10mm x 60mm, x2 10mm x 70mm,
x3 8mm x 95mm socket head cap screw. x3 10mm flat
washer, x2 10mm nyloc nut.*

Tools needed:

- 3/8" drive ratchet/impact.
- 3/8" drive medium extension..
- 3/8" #8 allen socket.
- 3/8" #6 allen socket.
- 3/8" drive torque wrench.

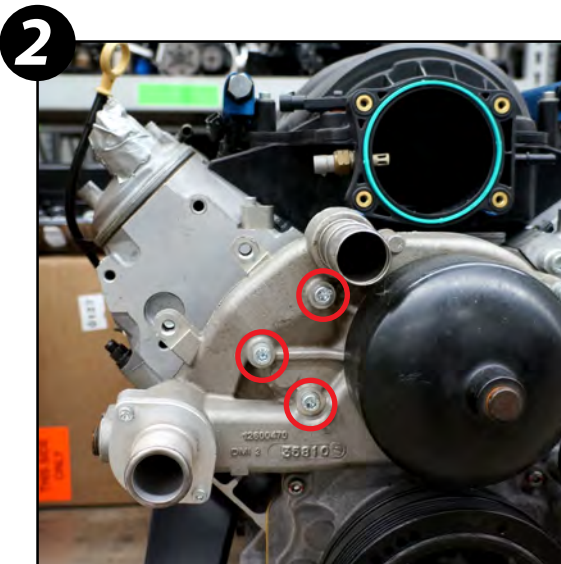
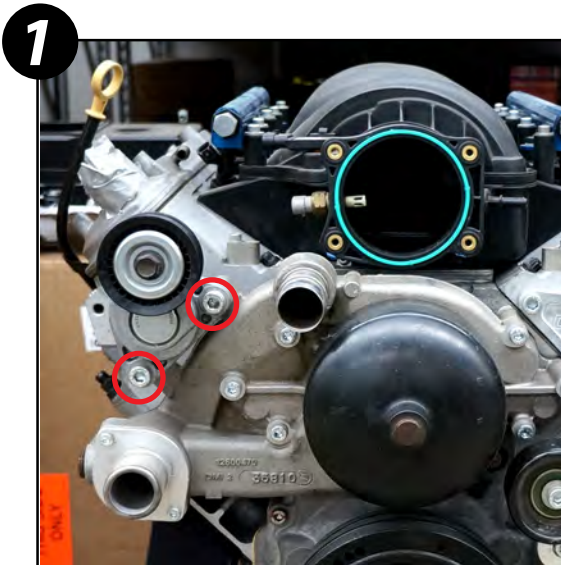

Prep.

Remove the accessory drive belt.

Remove the factory belt tensioner attached to the water pump by removing the two bolts highlighted in step one.

Remove the three bolts from the front of the water pump highlighted in step two. *Water pump may leak when bolts are removed.*

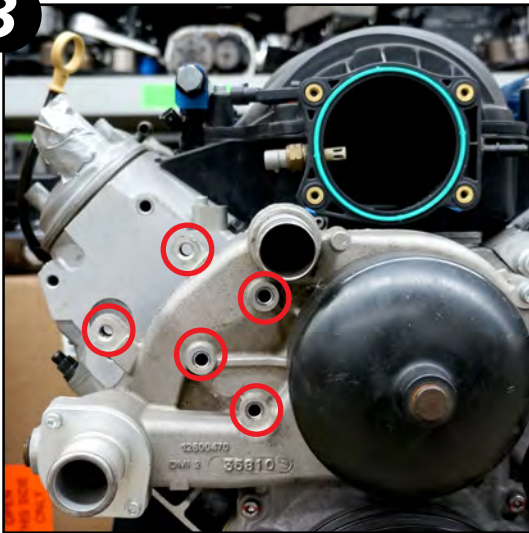
3

Prep cont.

You should now have 5 mounting holes on the front the water pump (step3).

Attach Bracket:

Line up the bracket to match the five holes on front of the water pump.

Insert x1 10mm x 60mm socket head cap screw (A, step 4), x1 10mm x 65mm socket head cap screw (B, step 4) though the bracket and thread into the water pump, hand tighten.

Insert the three 8mm x 95mm socket head cap screws (C, step 4) though the bracket and thread into the front of water pump, hand tighten.

Wench tighten and torque to: **A**=35 ft lbs
B=20 ft lbs

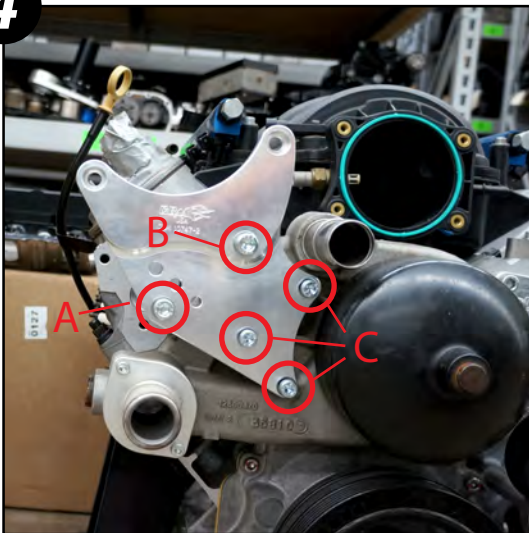
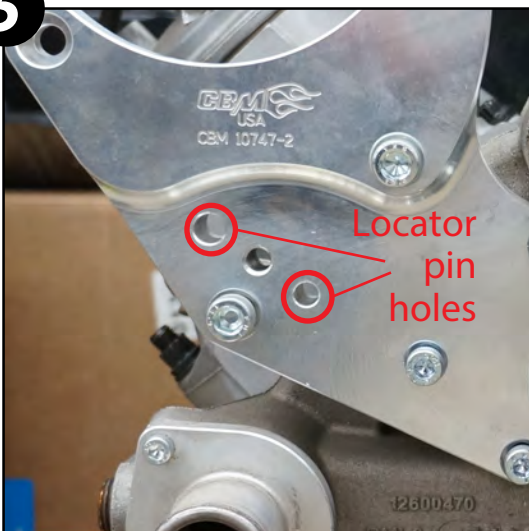
4**5**

Attach Tensioner:

With the bracket bolts torqued and flush with the bracket surface, note where the tensioner locator pin holes are at (step 5).

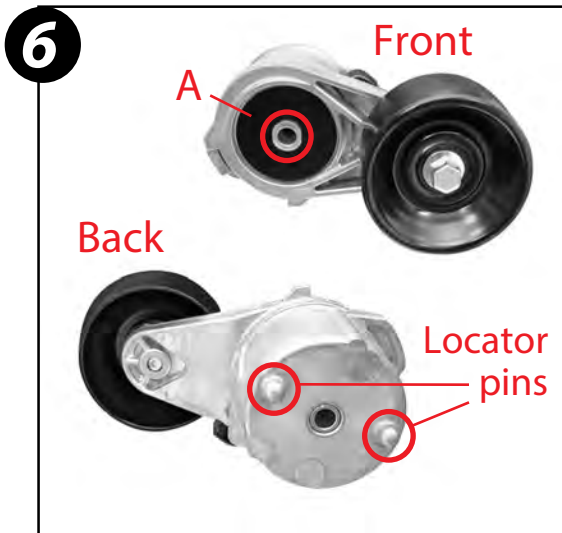

Attach Tensioner cont:

Using the tensioner locator pins on the back of the tensioner (step 6) line up the tensioner with the pins to the locator holes on the bracket. Insert x1 10mm x 70mm socket head cap screw through the front of the tensioner (A step 6/7) and thread into the bracket .

Torque to: A=30 ft lbs.

Verify your work, no gaps between bracket spacers and water pump, tensioner alignment correct.

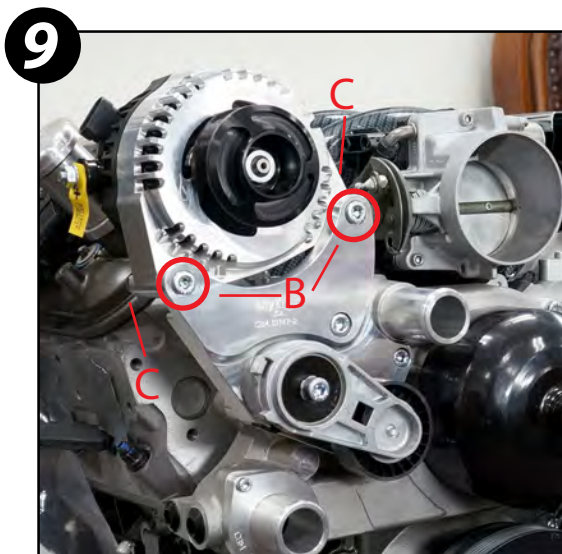
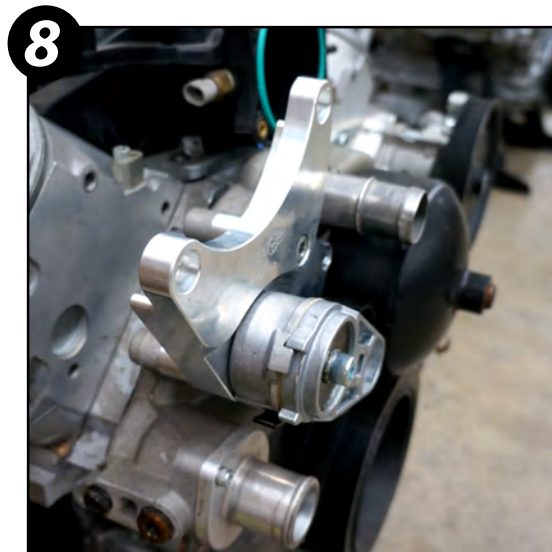
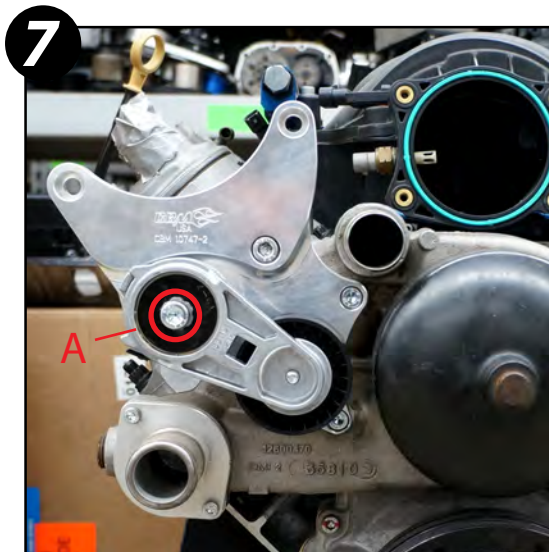

Attach Alternator:

Line up the alternator to the bracket and insert x2 10mm x 70mm socket head cap screws through front of bracket and through the alternator (B, step 9) install the washers and nyloc nuts (C, step 9).

Torque to: B/C=35 ft lbs.

Verify your front accessory belt drive pulleys line up.



Billet LS Alternator Bracket

High Mount Passenger Side Kit

Tech Support

Telephone:
909.291.7550 ext.2001

Email:
chris@custombuiltmotors.com

Warranty

CBM Motorsports™ products are warranted to be free from defects in material and workmanship for a period of 90 days from the date of purchase. CBM Motorsports™ electronic components and products are warranted to be free from defects in material and workmanship for a period of 30 days from the date of purchase.

More From

Available at CBMmotorsports.com



#CBM-10449-KIT

GM LS DECK PLATE LS1, LS2, LS3, LS7, LSX, L92, L96 4.200



#CBM-12345

LS1 LS2 LS3 LS7 FRONT AND REAR COVER ALIGNMENT TOOL SET



#CBM-11229

GEN III GEN III GM LS ENGINE LIFT PLATE



#CBM-11226

GM LS ENGINE STANDS SHORT



#CBM-11328

CYLINDER SLEEVE PULLER GM LS7, LSX, RHS, BODIX, WARHAWK



#CBM-10452-D

LS3, LS7, LS9 DRY SUMP OIL PUMP ALIGNMENT TOOL